

**BULKHEAD PLUG RECEPTACLE PANEL SEAL**  
**FRONT MOUNT. - WITH SOLDER POT CONT+ TAG**

**R141.580.000**

Series : BNC

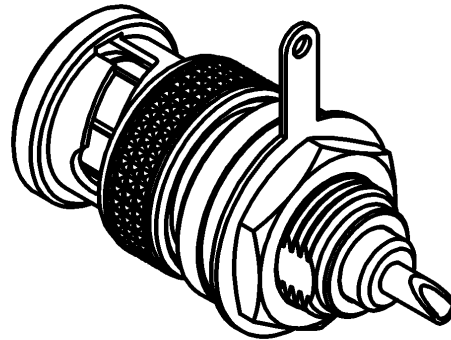
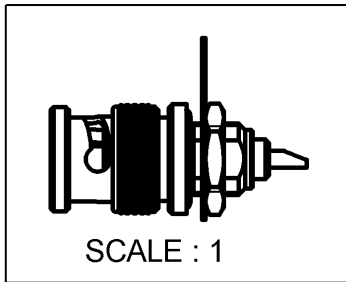
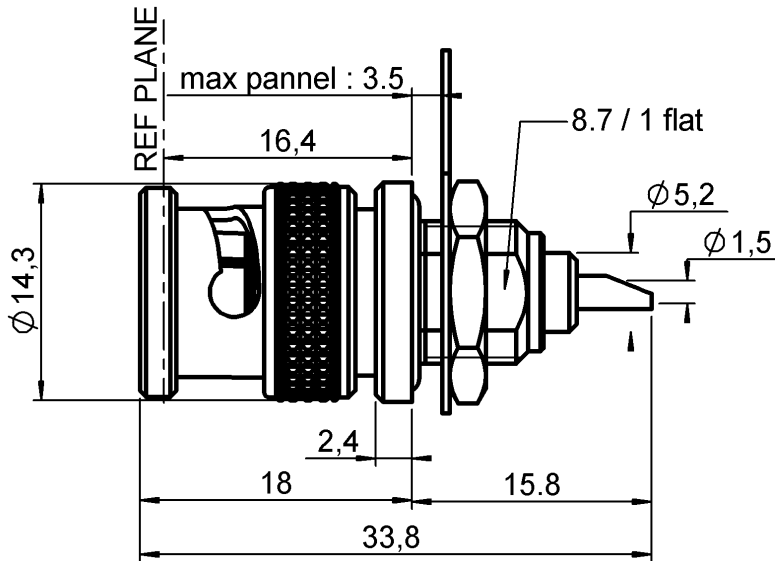

**PANEL CUT OUT**

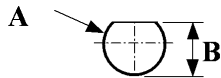

mm		
	Maxi	mini
<b>A</b>	9.75	9.65
<b>B</b>	4.04	3.96

All dimensions are in mm.



COMPONENTS	MATERIALS	PLATING (µm)
BODY	BRASS	NICKEL 2
CENTER CONTACT	BRASS	GOLD 0.5 OVER NICKEL 2
OUTER CONTACT	-	-
INSULATOR	PTFE	-
GASKET	SILICONE RUBBER	-
OTHERS PARTS	BRASS	NICKEL 2
-	-	-
-	-	-

Issue : 0628 C

In the effort to improve our products, we reserve the right to make changes judged to be necessary.



**BULKHEAD PLUG RECEPTACLE PANEL SEAL  
FRONT MOUNT. - WITH SOLDER POT CONT+ TAG**

**R141.580.000**

Series : BNC

**PACKAGING**

Standard	Unit	Other
<b>100</b>	<b>'W' option</b>	<b>Contact us</b>

**SPECIFICATION**

**ELECTRICAL CHARACTERISTICS**

Impedance		<b>50</b> Ω
Frequency		<b>0-4</b> GHz
VSWR	<b>1.06 +</b>	<b>0,0060</b> x F(GHz) Maxi
Insertion loss		<b>.025*</b> √F(GHz) dB Maxi
RF leakage	- (	<b>57</b> - F(GHz)) dB Maxi
Voltage rating		<b>500</b> Veff Maxi
Dielectric withstanding voltage		<b>1500</b> Veff mini
Insulation resistance		<b>5000</b> MΩ mini

**CABLE ASSEMBLY**

Stripping	a	b	c	d	e	f
mm	0,00	0,00	0,00	0,00	0,00	0,00

Assembly instruction : **NA**

Recommended cable(s)

**MECHANICAL CHARACTERISTICS**

Center contact retention		
Axial force – Mating end	<b>18</b>	N mini
Axial force – Opposite end	<b>18</b>	N mini
Torque	<b>2.8</b>	N.cm mini

Characteristics indicated on this data sheet are those that can be achieved with the highest performance cable. Intrinsic limitations of the cable may diminish the performance of the assembly

Cable retention

- pull off	<b>NA</b>	N mini
- torque	<b>NA</b>	N.cm

**TOOLING**

Recommended torque		
Mating	<b>NA</b>	N.cm
Panel nut	<b>250</b>	N.cm
Clamp nut	<b>NA</b>	N.cm
A/F clamp nut	<b>0,0000</b>	mm

Part Number	Description	Hexagon
.	.	.

**OTHER CHARACTERISTICS**

Mating life	<b>500</b>	Cycles mini
Weight	<b>11,0000</b>	g

\* Coaxial Transmission Line Only

**ENVIRONMENTAL**

Operating temperature	<b>-65/+165</b>	° C
Hermetic seal	<b>NA</b>	Atm.cm3/s
Panel leakage	<b>NA</b>	

Issue : 0628 C

In the effort to improve our products, we reserve the right to make changes judged to be necessary.

